

(No Model.)

2 Sheets—Sheet 1.

T. F. CLEMONS.  
STONE TURNING LATHE.

No. 274,563.

Patented Mar. 27, 1883.

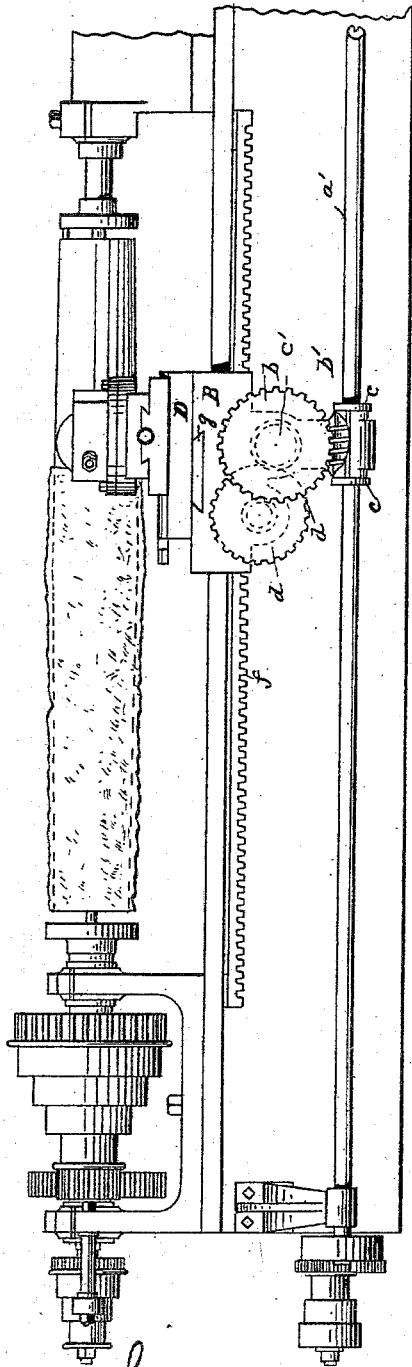

FIG. 1-

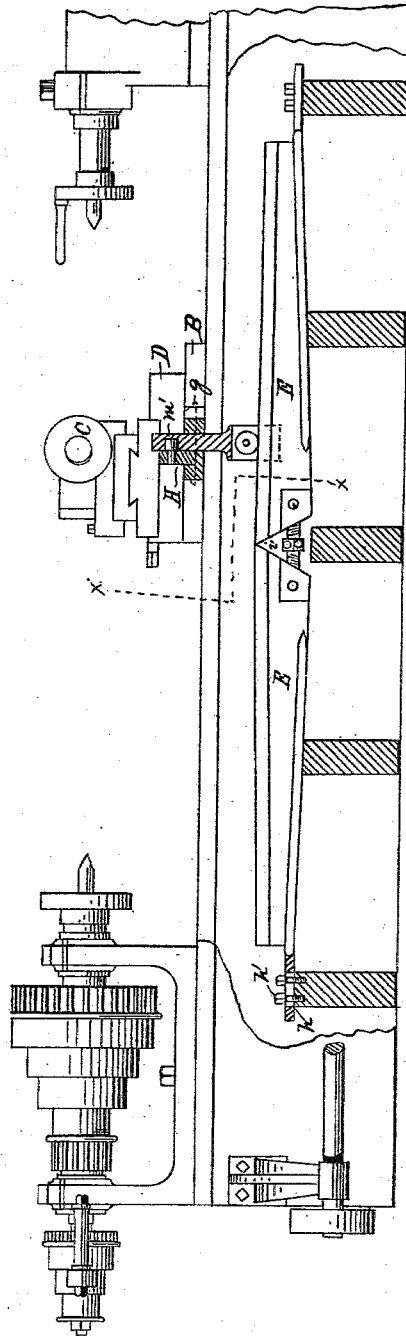

FIG. 2-

WITNESSES  
*Wm. H. ...*  
*Edward ...*

INVENTOR  
*T. F. Clemons*

(No Model.)

2 Sheets—Sheet 2.

T. F. CLEMONS.  
STONE TURNING LATHE.

No. 274,563

Patented Mar. 27, 1883.

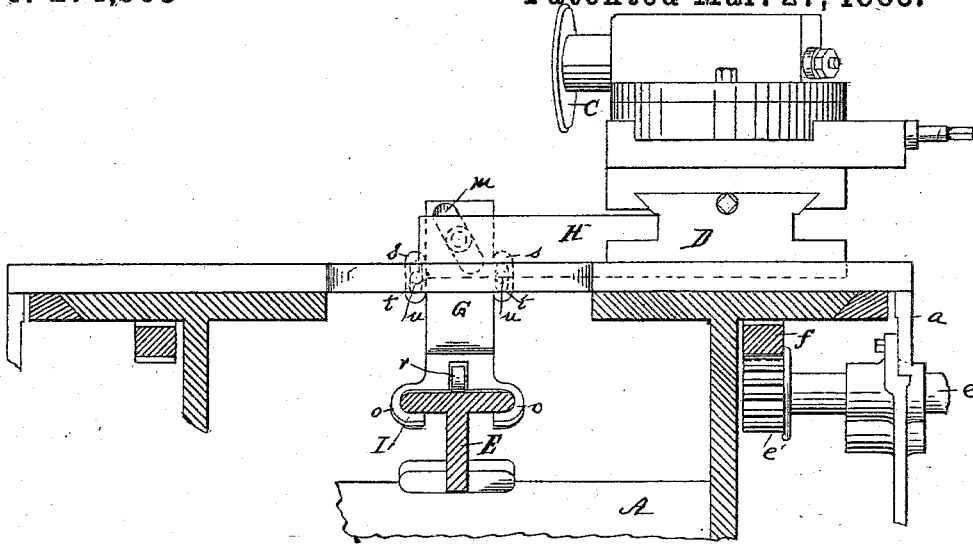

Fig. 3.

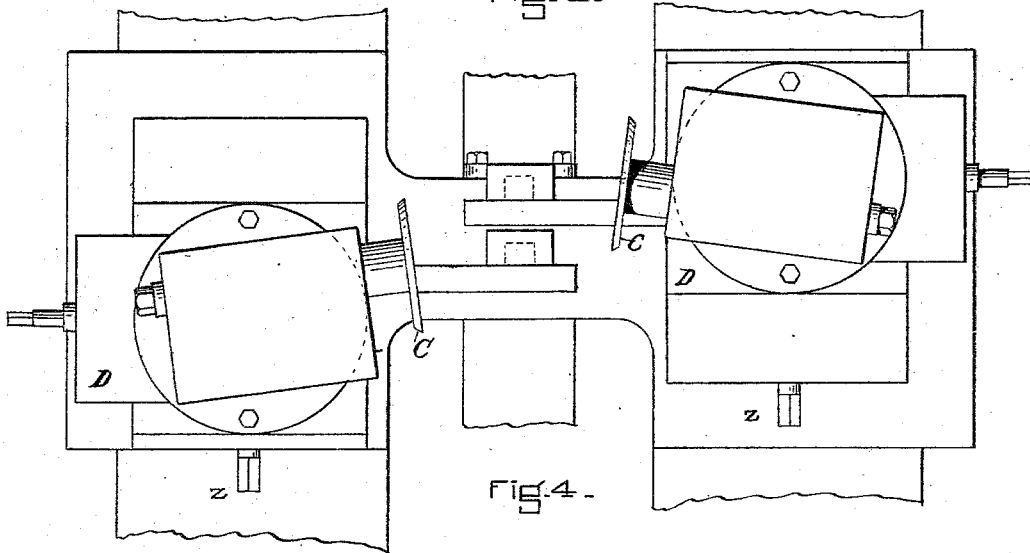

Fig. 4.

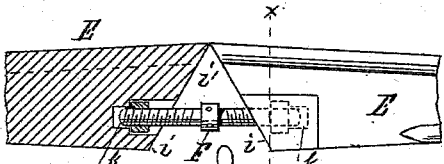

Fig. 5.

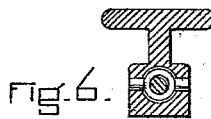

Fig. 6.

WITNESSES

*Edward J. Rouse*  
*Edward J. Rouse*

INVENTOR

*Thos. F. Clemons*

# UNITED STATES PATENT OFFICE.

THOMAS F. CLEMONS, OF TIVERTON, COUNTY OF DEVON, ENGLAND, AS-  
SIGNOR TO A. C. BALDWIN, OF BOSTON, MASSACHUSETTS.

## STONE-TURNING LATHE.

SPECIFICATION forming part of Letters Patent No. 274,563, dated March 27, 1883.

Application filed December 4, 1882. (No model.)

To all whom it may concern:

Be it known that I, THOMAS F. CLEMONS, a subject of the Queen of Great Britain and Ireland, residing at Tiverton, in the county of Devon and Kingdom of Great Britain and Ireland, have invented certain new and useful Improvements in Stone-Turning Lathes; and I do declare the following to be a full, clear, and exact description of the invention, such as will enable others skilled in the art to which it appertains to make and use the same, reference being had to the accompanying drawings, and to the letters and figures of reference marked thereon, which form a part of this specification.

My invention relates to improvements in guides or pattern-plates for lathes for turning tapers or forms in stone columns or other material, and is designed as an improvement on the machine shown in Letters Patent No. 265,581, dated October 10, 1882, granted to E. R. Cheney.

The object of my invention is to control both cutter-heads by a single guide or pattern bar running longitudinally through the center of the lathe-bed, said bar being made adjustable, so as to give to the column any desired shape or taper.

My invention consists in an adjustable central guide or pattern bar, to which the cutter-carrying frames are movably secured by a slotted hanger which is carried along by the cutter-carrying frames, whereby the cutters are automatically moved toward or from the stone to give to the stone the required taper or shape.

My invention consists, further, in certain details of construction hereinafter more fully set forth, and pointed out in the claims.

Figure 1 is a side elevation of a portion of a stone-lathe, showing a column and automatic feed device for the cutters and cutter-carrying frames which I prefer to use. Fig. 2 is a longitudinal sectional view, showing the guide or pattern bar. Fig. 3 is a cross-section on the line *xx* of Fig. 2. Fig. 4 is a plan view. Fig. 5 is a sectional view of a portion of the guide or pattern bar partly in section. Fig. 6 is a transverse vertical sectional view on the line *x'x'* of Fig. 5.

In the patent to Cheney, above referred to, a pattern device is shown consisting of three

bars or pattern-surfaces of a shape necessary to form two slots or grooves of an equal width throughout, in each of which slots or grooves a roller connected by a bolt or pin to the cutter-head traveled longitudinally, thus moving the cutter-heads toward or from the stone and giving the required shape to the columns. The said bars or pattern-surfaces, being firmly bolted inside of the lathe-bed, were only capable of forming one shape or pattern of column. This, in case of a great variety of column shapes being needed, necessitated the employment of one or more skilled workmen in making pattern-surfaces. The lathe-bed and appliances for revolving the material, as well as for feeding the mechanism to the material to be operated upon, together with the chucks for holding the material, the cutters, and cutter-holders, form no part of my invention, and consequently a full detailed description of these parts is deemed unnecessary, and only so much will be described as will be necessary to describe my improvements as applied to the class of lathe-beds shown in the drawings.

A is a lathe bed or frame provided with the usual chucks for holding the material to be operated upon, and with mechanism for imparting motion thereto. The lathe-bed is provided with a sliding plate, B, which is connected at both ends to operating mechanism by a pendant or arm, *a*, which embraces the grooved rods or shafts *a'*. The pendant *a* is provided with a gear-wheel, *b*, which engages with a worm wheel or gear, *b'*, on the shaft or grooved rods *a'*. The worm wheel or gear *b'* is located within the arms *cc* of the pendant *a*, and is provided with a tongue for engagement with the grooves in the rods or shafts *a'*. The shaft *c'*, on which the gear-wheel is mounted, is provided with a small pinion-wheel, *d*, (shown in dotted lines in Fig. 1,) which meshes with a gear-wheel, *d'*, mounted on a shaft, *e*, which has its bearing in the pendant *a*. The inner end of the shaft *e* is provided with a gear-wheel, *e'*, which meshes with the rack *f* on the lathe-frame, so that by the rotation of the shafts or rods *a'* the plate B is caused to travel back or forth on top of the lathe-bed.

C C are the cutters, secured to appropriate axes, and mounted on adjustable beds D D in such a manner that the cutters may be

turned to any desired angle or moved back and forth, to and from the stone, in ways in the plate D, provided for that purpose, as shown at *g*, Figs. 1 and 2.

5 I have given this detailed description of the feeding and adjusting mechanism for the purpose of more clearly illustrating my invention; but these devices form no part of my invention.

10 E E are guide or pattern bars adjustably secured to the central portion of the lathe-bed A. These guide or pattern bars are provided with a flanged upper surface, for a purpose which will be more fully hereinafter explained.

15 As above stated, the pattern-bars are adjustably secured to the base A by means of slots *h* and screw-bolts *h'*, by which means the bars are capable of longitudinal adjustment. The bars E E are beveled at their inner ends, as

20 shown at *i* in Figs. 2 and 5, so as to form a V-shaped recess, *i'*. The inner ends of the bars E E are coupled together by means of a right-and-left-hand screw-bolt, F, which meshes with appropriate screw-threads or nuts

25 secured in the cavities *k* in the ends of the bars E E, so that by loosening the bolts *h'* and turning the screw-bolt F the inner ends of the bars E E may be raised or lowered to any desired angle within prescribed limits, in which

30 position they may be secured by tightening up the bolts *h'*.  
G is a hanger, which is loosely connected to the arm H of the cutter-carrying beds D by means of a diagonal slot, *m*, in the hanger,

35 and a headed pin, *m'*, with friction-roll secured to the arm H and adapted to move back and forth in the slot *m*. The lower part of the hanger G is bifurcated or provided with hooks which project under the head I of the bars E,

40 so as to support and steady the hanger G. The hanger G is also provided with a friction-wheel, *r*, which rests upon the top of the bar E, so that the hanger will more readily move back and forth on the bar E. The hangers G are

45 also provided with side lugs, *s*, in which are formed the slots *t* for the reception of the bolts *u*, (see dotted lines in Fig. 3,) by which means the hanger is secured firmly as against lateral displacement, while at the same time it is free

50 to move up and down in a vertical line.

The operation of my devices is as follows:

The bars E E having been secured in the proper position to give the desired taper or shape to the column, the machine is set in motion and the cutter-carrying devices are fed

55 forward. The hanger G, in ascending the inclined portions of the bars, is pushed up, and by means of the pin *m'*, working in the slot *m*, the cutter-carrying bed D is forced from the stone, carrying with it the cutters, and thus

60 the desired depth of cut is given to the cutters, and columns of varying peripheral outline may be formed with ease and without the aid of an attendant to watch the pattern-bars, and,

65 furthermore, one set of pattern-bars is all that is necessary to produce a variety of tapers or forms in the article to be turned.

Having thus described my invention, what I claim, and desire to secure by Letters Patent, is—

70 1. In lathes for turning tapering columns or shapes of stone or other material, a central guide or pattern bar, the pitch of the incline of which is vertically adjustable, said bar being connected to the cutter-carriage by means

75 of an adjustable arm having a slot therein, the pitch or angle of which slot determines the taper or peripheral outline of the article to be shaped, as set forth.

2. The guide or pattern bars herein described, 80 adjustably connected to the frame of the machine at their outer ends, said bars being beveled at their inner ends, and connected to each other by a right-and-left-hand screw-bolt, by means of which the abutting ends of the bars

85 are raised or lowered, as set forth.

3. The combination of the adjustable guide or pattern bars E E and slotted hanger G, movably connected to said pattern-bars, and adapted to travel back and forth thereon, with

90 the arm H and cutter-carrier D, as set forth.

In testimony whereof I affix my signature in presence of two witnesses.

THOMAS F. CLEMONS.

Witnesses:

ARNOLD A. RAND,  
EDWARD J. JONES.